



SECURITY BY DESIGN >>

LBA ROC

FIXED BOLLARD WITH SHELL

Ø 279 mm - H - 600 mm

- Fixed bollard concealed under a design cover
- High protection thanks to reinforced cylinder and floor anchoring
- Resistance 138 KJ, stops 1.5T vehicle at 50 km/h

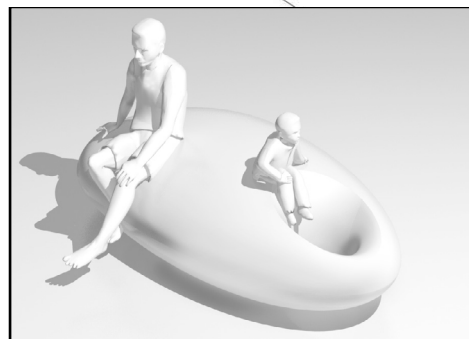

Specifications

Technical features

Principle:

ROc, is a pebble that looks like it is polished by time. It **protects** public spaces and users from vehicle attacks but remains **invisible** without adding anxiety. This biophilic shaped urban furniture appropriates the public space as an object that inhabits it differently

Fixed bollard structure:

Steel sheet of Ø 279 mm, thickness of 16 mm, cathaphoresis treatment and RAL 7021 epoxy powder painting, other colors in option

Shell structure:

Innovative eco-active material: a last-generation synthetic resin; it contributes to the health of users by purifying the surrounding environment. It is **antibacterial, self-cleaning** and **eliminates toxic chemicals** by simple contact.

Dimensions:

Shell: 3000x1600x765
Fixed bollard: Ø 279 mm - H - 600 mm

Security by Design:

This bollard is part of a **Security By design** approach, expertise which consists in taking into account all the existing threats and risks, imperatives and constraints both architectural and functional of a site, to advocate **efficient security solutions**. The protection of users does not reinforce the insecure anxietyfeeling, thanks to a concealed bollard hidden into the urban landscape.

LBA ROC FIXED BOLLARD WITH SHELL

Ø 279 mm - H - 600 mm

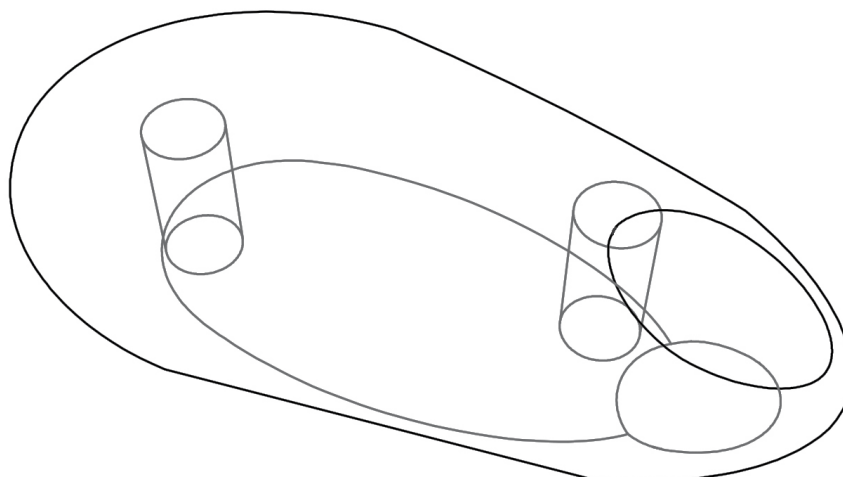

INSTALLATION

Sleeving and conduits:

- Power supply (option) :**
 - Janolène Ø 63 mm
 - U 1000 RO 2V cable 3 x 2.5 mm²

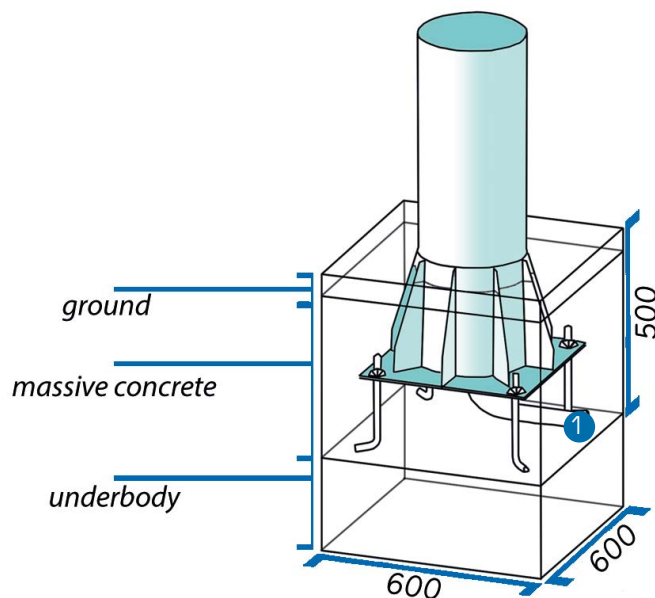

WORK TO BE CONDUCTED BY THE INSTALLER:

Massive concrete and for anchoring.
Power cables for LEDs cover